

ME-3 Metal Clad Wiper

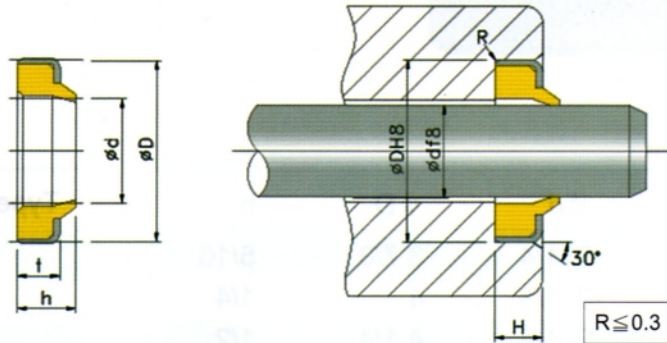

Surface Roughness
Rod Surface 0.8~1.6 μ mRmax(0.2~0.4 μ mRa)

Mechanical Properties

- Material:K-90
- Specific Gravity(ASTM D792):1.21
- Hardness(ASTM D2240):90 \pm 2
- Tensile Strength(ASTM D412):659
- 100% Modulus(ASTM D412):73
- 300% Modulus(ASTM D412):183
- Compression Set22h/70°C(ASTM D395):33
- Compression Set22h/100°C(ASTM D395):49

Influence of Temperature on Hardness (Shore A)

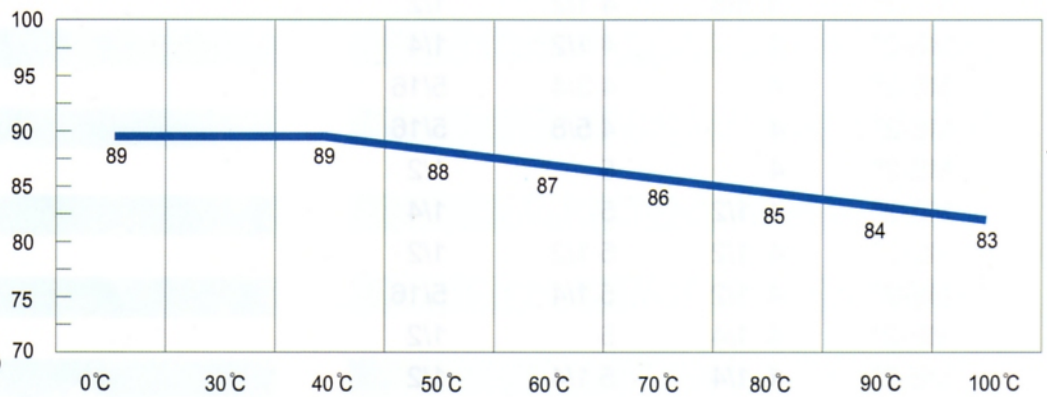

Working Conditions

- Working Speed:0.03~1.0 m/sec
- Working Temp.: -20~100°C

Oil Resistance

- Testing Oil:Hydraulic Oil
- Material:K-90
- Testing Temp. (°C) : 100/120
- Testing Time(Hour): 100/100
- Hardness Variation (Shore A) : 0/-1
- Tensile Strength Variation(%): -22/-42
- Volume Variation(%): -0.3/-0.5

Compression Set

