



## Type TGHG202

### Apply Range

**Annular Seal Pressure:** P= 14.50 ~ 36.25 PSI

**Annular Seal Temperature:** t = -40°C ~ 200°C

**Rotation Speed:** n ≤ 500r/min

**Medium:** Acid, Alkali, Oil and Macromolecule suspend medium.

### Agitador Mechanical Seals

- Multiple Springs
- Externally Mounted Seal
- Single Face
- Unbalanced Structure

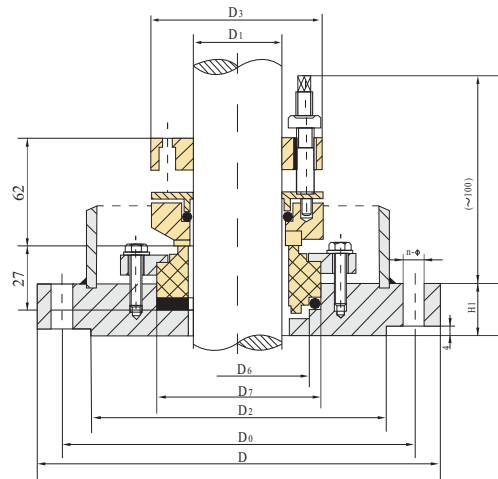

### TGHG202

Mounting dimension (The dimension of joined agitador orifice is according to the standard of HG5-754-78)

(Specification)	(Size)	D <sub>1</sub> (h8)	D	D <sub>0</sub> (±0.5)	D <sub>2</sub> (h11)	D <sub>3</sub> (max)	D <sub>6</sub> (A11)	D <sub>7</sub> (H8)	H <sub>1</sub>	n-φc
TGHG202-30	30	30	185	150	116	66	51	60	20	4-φ 18
TGHG202-40	40	40	225	170	135	76	61	70	20	4-φ 18
TGHG202-50	50	50	235	200	164	88	71	80	22	8-φ 18
TGHG202-65	65	65	235	200	164	103	86	97	22	8-φ 18
TGHG202-80	80	80	260	225	188	118	102	112	22	12-φ 18
TGHG202-95	95	95	290	225	220	135	117	127	24	12-φ 18
TGHG202-110	110	110	315	280	245	150	132	142	24	12-φ 18

